

---

## Manual of 2-phase hybrid stepper motor driver DQ542MA



### Introduction:

DQ542MA is a type of two-phase hybrid stepping motor driver, the drive voltage of which is from 18VDC to 50VDC. It is designed for use with 2-phase hybrid stepper motor of all kinds with 42mm to 86mm outside diameter and less than 4.0A phase current. This circuit that it adopts is similar to the circuit of servo control which enables the motor run smoothly almost without noise and vibration. Holding torque when DQ542MA run under high speed is also significantly higher than the other two-phase driver, what's more, the positioning accuracy is also higher. It is widely used in middle and big size numerical control devices such as curving machine, CNC machine, Computer embroider machine, packing machines and so on.

### Features:

High performance, low price

Average current control, 2-phase sinusoidal output current drive

Supply voltage from 18VDC to 50VDC

Opto-isolated signal I/O

---

Overvoltage, under voltage, overcurrent, phase short circuit protection

15 channels subdivision and automatic idle-current reduction

8 channels output phase current setting

Offline command input terminal

Motor torque is related to speed, but not related to step/revolution

High start speed

High holding torque under high speed

Electrical specification:

Input voltage	18-50VDC
Input current	< 4A
Output current	1.0A ~ 4.2A
Consumption	Consumption : 80W ; Internal Insurance : 6A
Temperature	Working Temperature -10 ~ 45°C ; Stocking temperature -40°C ~ 70°C
Humidity	No condensation, no water droplets
gas	Prohibition of combustible gases and conductive dust
weight	300GS

1. Pins assignments and description:

1) Connector Pins Configurations

Pin Function	Details
PUL +,PUL-	Pulse signal, PUL+ is the positive end of pulses input pin PUL- is the negative end of pulse input pin
DIR+,DIR-	DIR signal: DIR+ is the positive end of direction input pin DIR- is the negative end of direction input pin
ENBL+	Enable signal: ENBL+ is the positive end of direction input pin. This signal is used for enabling/disabling the driver. High level for enabling the driver and low level for disabling the

	driver.
ENBL-	ENBL- is the negative end of direction input pin. Usually left unconnected (enabled)

2) Pins wiring diagram:

PC's control signals can be active in high and low electrical level. When the high electrical level is active, all control negative signals will be connected together to GND. When low electrical level is active, all control positive signals will be connected together to public port. Now give two examples ( Open collector & PNP), please check them:

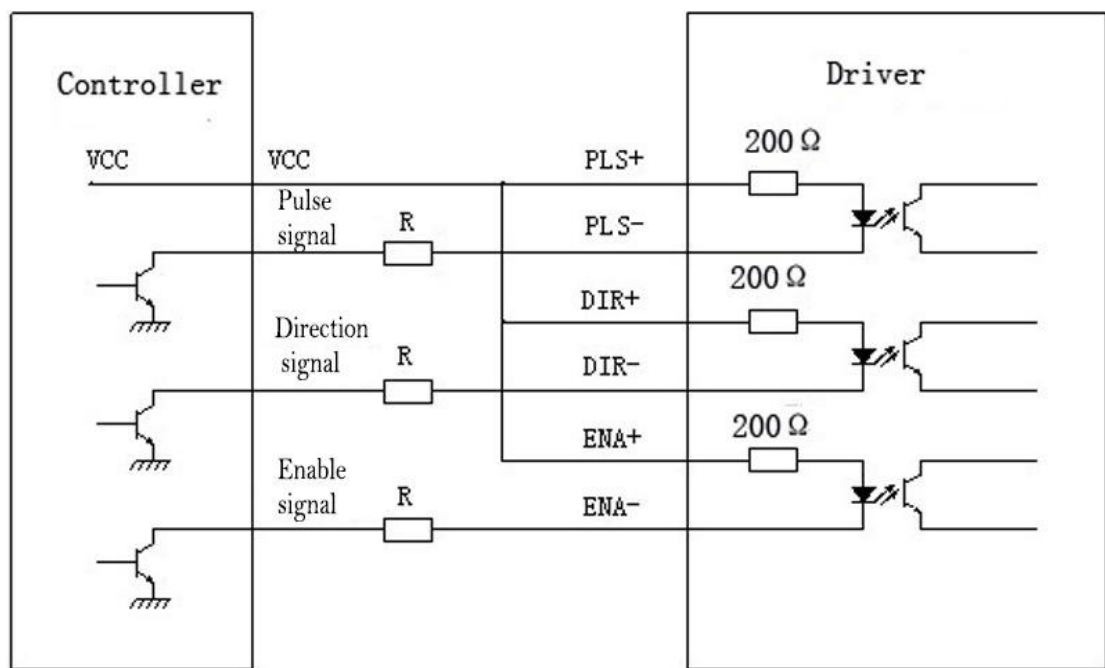

Fig 1. Input port circuit (Yang connection)

PC open connector output

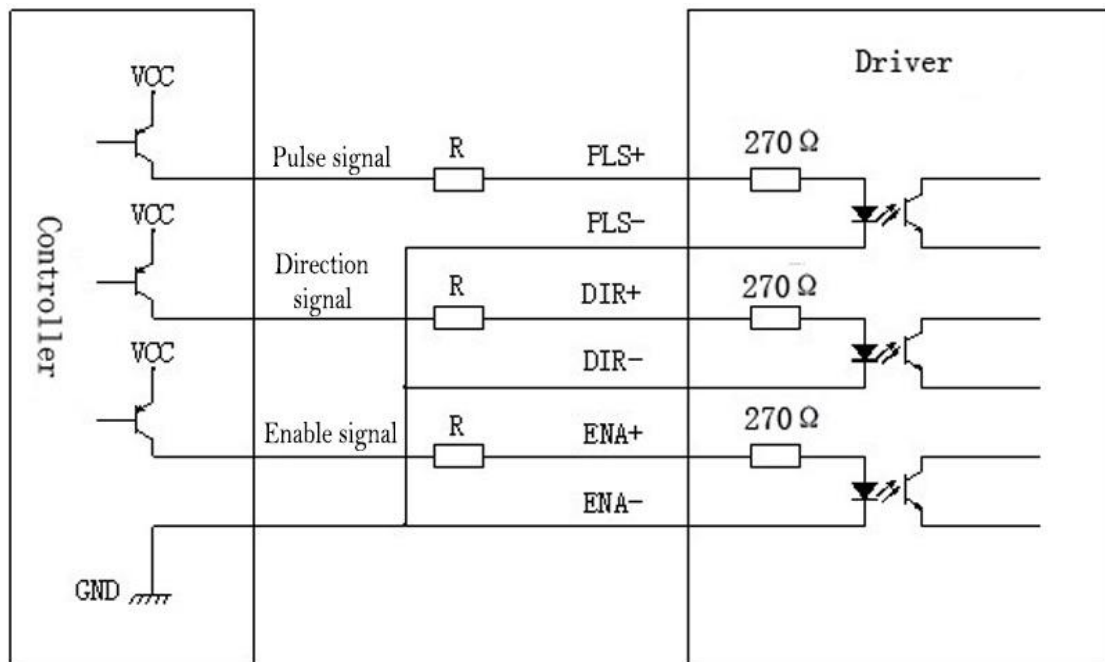

Fig. 2 Input port circuit ( Yin connection)

PC PNP output

Note: When VCC=5V, R=0

When VCC=12V, R=1K, > 1/8W

When VCC=24V, R=2K, > 1/8W

**R must connect in the control signal part.**

### 3. Function choice ( Using DIP pins to achieve this function)

1) Micro step resolution is set by SW 5,6,7,8 of the DIP switch as shown in the following table:

:

SW5	OFF	ON	OFF	ON	OFF	ON	OFF	ON	OFF	ON	OFF	ON	OFF	ON	OFF
SW6	ON	OFF	OFF	ON	ON	OFF	OFF	ON	ON	OFF	OFF	ON	ON	OFF	OFF
SW7	ON	ON	ON	OFF	OFF	OFF	OFF	ON	ON	ON	ON	OFF	OFF	OFF	OFF
SW8	ON	ON	ON	ON	ON	ON	ON	OFF	OFF	OFF	OFF	OFF	OFF	OFF	OFF
PULSE/RE V	400	800	1600	3200	6400	12800	25600	10000	20000	40000	50000	80000	100000	200000	250000

### 2) Standstill current setting

---

SW4 is used for this purpose. OFF meaning that the standstill current is set to be half of the selected dynamic current and ON meaning that standstill is set to be the same as the selected dynamic current.

### 3) Output current setting:

The first three bits (SW 1, 2, 3) of the DIP switch are used to set the dynamic current. Select a setting

Closest to your motor's required current

Output current (A)				
SW1	SW2	SW3	PEAK	RMS
ON	ON	ON	1.00	0.71
OFF	ON	ON	1.46	1.04
ON	OFF	ON	1.91	1.36
OFF	OFF	ON	2.37	1.69
ON	ON	OFF	2.84	2.03
OFF	ON	OFF	3.31	2.36
ON	OFF	OFF	3.76	2.69
OFF	OFF	OFF	4.20	3.00

### 4) Semi-flow function:

Semi-flow function is that there is not step pulse after 500 ms, the driver output current automatically reduced to 70% of rated output current, which is used to prevent motor heat.

### 4. Power connections

(1)+V、 GND : Power Supply.

+V: Power supply, 16~50 VDC, Including voltage fluctuation and EMF voltage. The max current is 5A.

(2) A+ A- B+ B- : Connecting 2 phase stepper motors.

The driver & 2-phase hybrid stepping motor use four-wire connection, the motor can be connected in parallel & series bipolar. As for bipolar connection, it is higher performance with high-speed, but the current of driver is larger (it is 1.73 times more than the motor's winding current).

Connecting in series, the driver's current is equal to the motor winding one.

### 5. Fixing

There should be 20mm of space, it can't be placed next to other heating devices, to avoid dust, oil mist, corrosive gas, humidity and strong vibration places.

(Unit=mm)

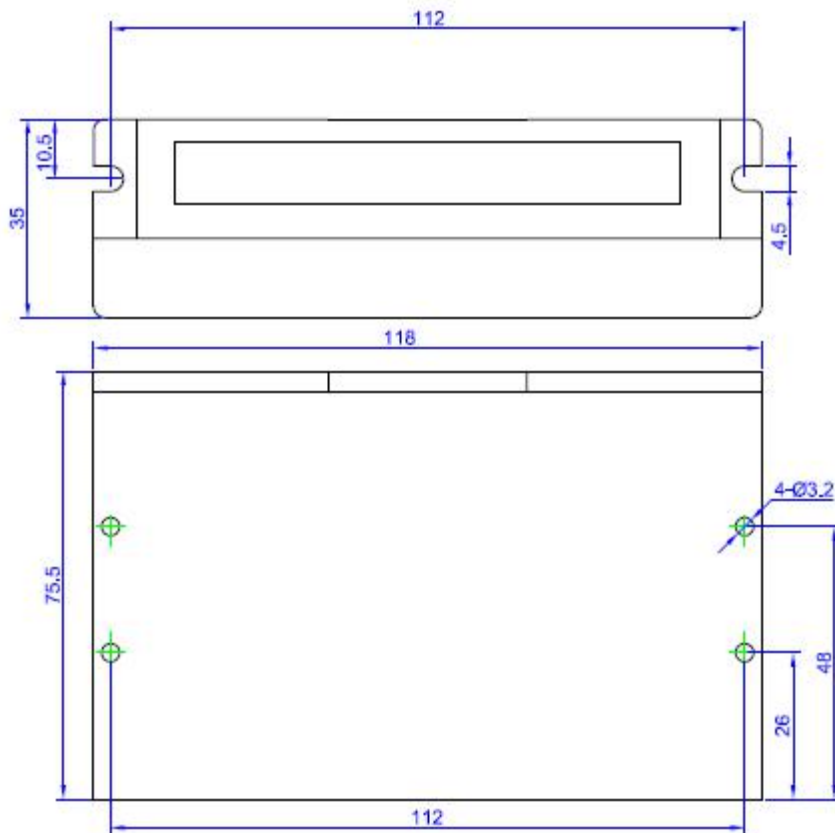

Picture 3

## 6. Troubleshooting

1, the status on light's indication

RUN: green, normal work light.

ERR: red, failure light, the motor with phase short-circuit, overvoltage and under-voltage protection.

2 Troubles

Alarm indicator	Causes	Measures
LED off turn	Wrong connection for power	Check wiring of power
	Low-voltages for power	Enlarge voltage of power
Motor doesn't run, without holding torque	Wrong connection of stepper motor	Correct its wiring

	RESET signal is effective when offline	Make RESET ineffective
Motor doesn't run, but maintains holding torque	Without input pulse signal	Adjust PMW & signal level
Motor runs wrong direction	Wrong wires' connection	Change connection for any of 2 wires
	Wrong input direction signal	Change direction setting
Motor's holding torque is too small	Too small relative to current setting	Correct rated current setting
	Acceleration is too fast	Reduce the acceleration
	Motor stalls	Rule out mechanical failure
	Driver does not match with the motor	Change a suitable driver

## 7. Driver Wiring

A complete stepper motor control system should contain stepper drives, DC power supply and controller (pulse source). The following is a typical system wiring diagram.

